

RECOMMENDED PANEL CUT-OUT

(SEE NOTE #7 & #9)

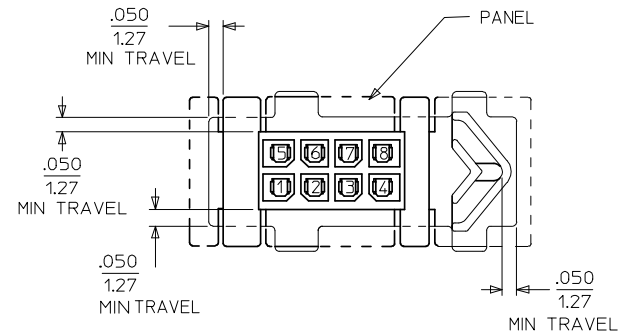

RECEPTACLE SHOWN MOUNTED IN PANEL

NOTES:

1. MATERIAL: UNFILLED POLYESTER (PBT), UL94V-0, COLOR: BLACK
2. FINISH: N/A
3. PRODUCT SPECIFICATION: PS-44300-001
4. PACKAGING SPECIFICATION TRAY PACKED PER PK-44133-002
5. THIS RECEPTACLE MATES WITH MOLEX BMI PLUG 44300, MOLEX BMI VERTICAL PCB HEADER 44432, MOLEX BMI RIGHT ANGLE PCB HEADER 44428, & MOLEX BMI CPI VERTICAL PCB HEADER 45280. (MOLEX DRAWINGS SD-44300-001, SD-44428-001, SD-44432-001, & SD-45280-001)
6. THIS RECEPTACLE TO BE USED WITH MOLEX FEMALE CRIMP TERMINALS ONLY. (MOLEX DRAWING SD-43030-****)
7. THIS RECEPTACLE IS DESIGNED FOR USE WITH .062/1.57 MAX. TO .050/1.27 MINIMUM THICK PANELS.
8. DIMENSIONS GIVEN ACROSS CENTERLINES ARE SYMMETRICAL ABOUT THOSE CENTERLINES WITHIN THE TOTAL TOLERANCE.
9. WHEN MATING WITH 44300 SERIES, THE PANEL CUT-OUT CENTERLINES OF DIM "H" AND .385/9.78 MUST ALIGN WITH POINT "M" DEFINED BY MOLEX DRAWING SD-44300-001.
10. MOLEX RECOMMENDS THE USE OF MICRO-FIT TEST PLUG (SERIES 44242) WHENEVER CONTINUITY TESTING IS PERFORMED. TEST PLUGS MUST NOT BE USED TO MAKE OR BREAK UNDER LOAD. MOLEX DOES NOT RECOMMEND USING STANDARD MATING COMPONENTS (SERIES 44428, 44432, 44300 OR 45280) FOR HARNESS TESTING PURPOSES.
11. HOUSINGS MAY EXHIBIT A SURFACE IMPERFECTION KNOWN AS "SINK MARKS" UP TO .024/(0.60) MAX. THIS IS A COSMETIC DEFECT AND DOES NOT EFFECT FUNCTION OF THE CONNECTOR.
12. THE WIDTH OF THE NARROW SLOTS SHOULD BE .114-.129/2.90-3.28 (MIN-MAX) IF KEYING OF THE CONNECTOR TO THE CUT-OUT IS DESIRED.

CKT. SIZE	MATERIAL NUMBER	DIM "A"	DIM "B"	DIM "G"	DIM "H"
04	44133-0400	.97 24.6	.118 3.00	.530 13.46	.870 22.10
06	44133-0600	1.09 27.7	.236 6.00	.648 16.46	.988 25.10
08	44133-0800	1.21 30.7	.354 9.00	.766 19.46	1.106 28.10
10	44133-1000	1.33 33.8	.472 12.00	.884 22.46	1.224 31.10
12	44133-1200	1.45 36.8	.591 15.00	1.002 25.46	1.343 34.10
14	44133-1400	1.57 39.9	.709 18.00	1.120 28.46	1.461 37.10
16	44133-1600	1.69 42.9	.827 21.00	1.239 31.46	1.579 40.10
18	44133-1800	1.81 46.0	.945 24.00	1.357 34.46	1.697 43.10
20	44133-2000	1.93 49.0	1.063 27.00	1.475 37.46	1.815 46.10
22	44133-2200	2.04 51.8	1.181 30.00	1.593 40.46	1.933 49.10
24	44133-2400	2.16 54.9	1.299 33.00	1.711 43.46	2.051 52.10

ADD NOTE 12 EC NO: UCP2009-0463 DRAWINGVERILL 2008/08/26 CHKD:HK/PPER 2008/08/26 APPR:FSM/LTH 2008/08/27 DESCRIPTION REV	QUALITY SYMBOLS ▽=0 ▽=0	GENERAL TOLERANCES (UNLESS SPECIFIED)	DIMENSION STYLE IN/MM	SCALE 4:1	DESIGN UNITS METRIC	THIRD ANGLE PROJECTION
				DRAWN BY SOMMER	DATE 1998/09/30	MICRO-FIT (3.0) BMI FLOATING PANEL RECEPTACLE, 4-24 CIRCUIT MOLEX INCORPORATED
				CHECKED BY SOMMER	DATE 1998/09/30	
				APPROVED BY EDGLEY	DATE 1998/09/30	
				MATERIAL NO.	DOCUMENT NO.	
			SHEET NO.			
		DRAFT WHERE APPLICABLE MUST REMAIN WITHIN DIMENSIONS	SIZE C	SEE CHART SD-44133-001		THIS DRAWING CONTAINS INFORMATION THAT IS PROPRIETARY TO MOLEX INCORPORATED AND SHOULD NOT BE USED WITHOUT WRITTEN PERMISSION